



Hydraulics

Torqmotor
Serie TK

ren schaffen jetzt 49kW

Kenndaten Serie TK

Drehzahl	5...520 U/min
Schluckstrom	max. 225 l/min
Eingangsdruck	max. 330 bar
Drehmoment	max. 2700 Nm
Seitenlast	max. 26000 N

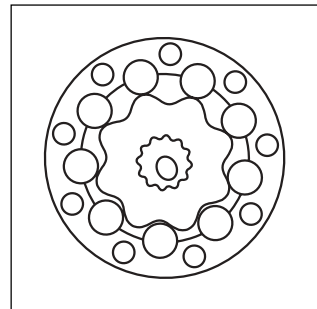

Serie TK bis max. 49kW

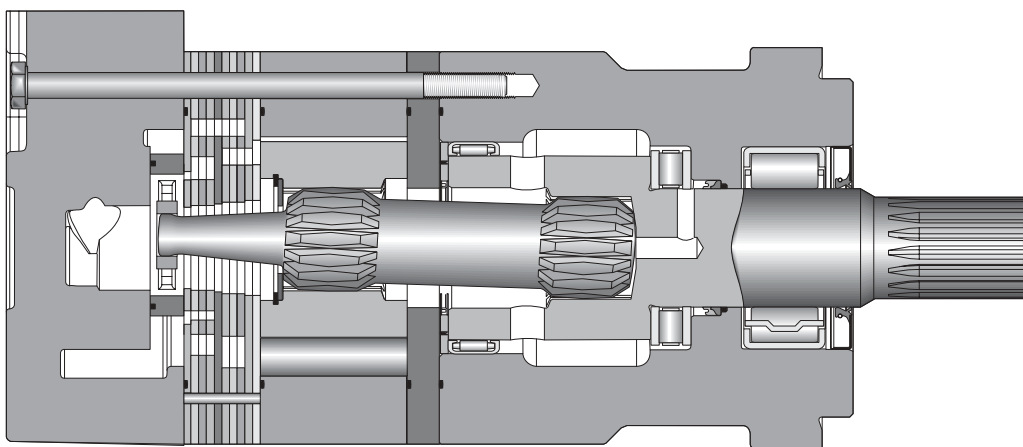

Anwendung z.B. in Radladern, ...

Serie TE bis 14kW

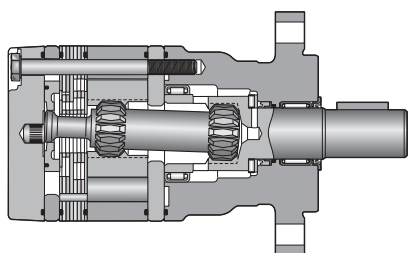

Anwendung z.B. in Kehrmaschinen, ...

Serie BG mit Bremse bis 33kW

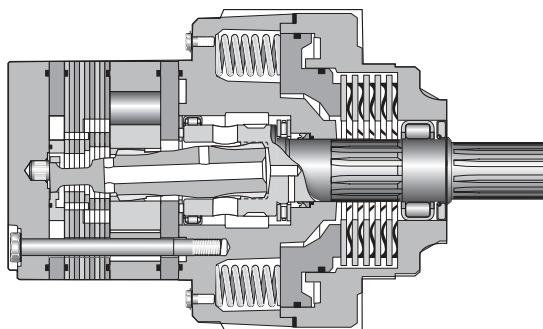

Anwendung z.B. in Scherenbühnen, ...

Serie TF / TG

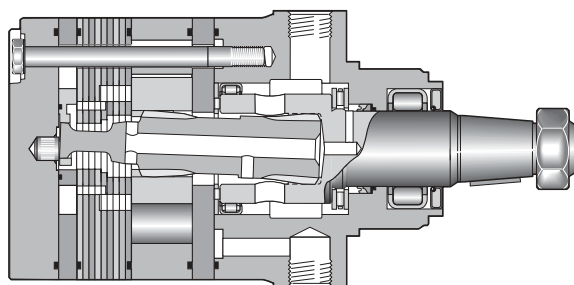

Anwendung z.B. in Winden, ...

Serie TH bis 33kW

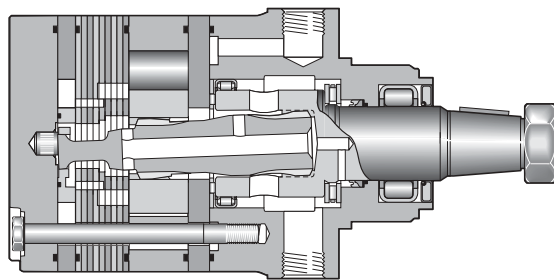

Anwendung z.B. in Kommunalfahrzeugen, ...